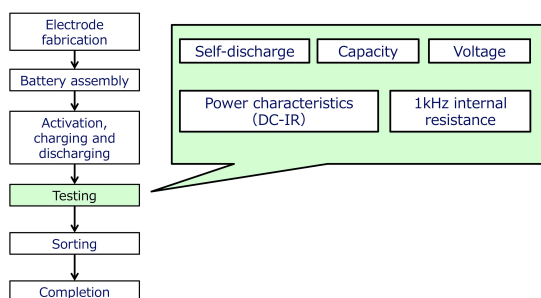


## From 1 hour to Just 10 Seconds: Using the Low-frequency AC-IR Method as a Quicker and More Stable Alternative to DC-IR Testing of Lithium Ion Batteries

*Lithium-ion batteries are emerging as the de facto technology for portable electronics, and manufacturers are scrambling to deliver their products as quickly as possible while improving quality to meet demanding applications. This paper discusses the shortfalls of the traditional DC-IR method for lithium-ion battery testing and offers an alternative method that cuts testing time down to 10 seconds while still maintaining measurement precision and stability.*

Recent development of lithium-ion battery applications has been brisk, leading to their use in a variety of applications. The characteristics of lithium-ion batteries vary with the application in which the cell is used, ranging from small batteries such as those used in smartphones with low capacity to large batteries with high capacity and low internal resistance. Form factors also vary by application, ranging from the standardized cylindrical 18650 to laminated and box-shaped batteries.



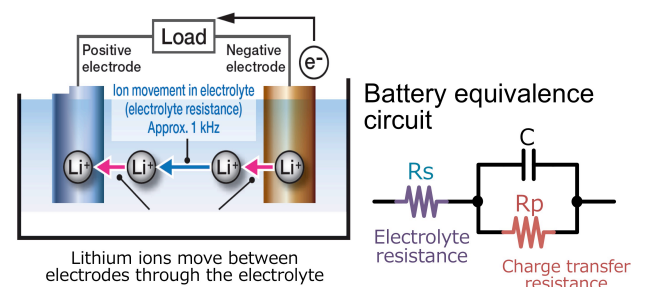
**Figure 1: Battery Production Process**

Figure 1 depicts the process by which batteries are produced. Generally, lithium-ion batteries are manufactured by means of the sequence of processes shown here. First, the electrodes and other components are fabricated, and the battery is assembled. Then, the battery is charged and discharged to activate it. At this point, the production process has yielded a functioning

battery.

Next, the batteries are tested and sorted according to their characteristics, and this stage marks the completion of the manufacturing process. However, manufacturers face a number of issues with the testing process. One such problematic test is the output characteristics test (DC-IR test). The primary issues faced by manufacturers are cycle time and stability, which has not been resolved with traditional testing methods.

In general, there are two methods for measuring a battery's internal resistance: the DC-IR method and the AC-IR method. The more common approach to battery testing is the use of the DC-IR method to test output characteristics, while the 1 kHz AC-IR method is used to test internal resistance.



**Figure 2: Lithium-ion battery schematic**  
**Chemical reaction on electrode surface**  
**charge transfer resistance: Approx.1Hz**

### THE INTERNAL RESISTANCE OF A BATTERY

When current flows from a battery, the chemical reactions illustrated in Figure 2 take place inside the battery. First, lithium ions move from inside the negative electrode into the electrolyte. Then, they move through the electrolyte and reach the positive electrode. Finally, they move from the electrolyte into the positive electrode.

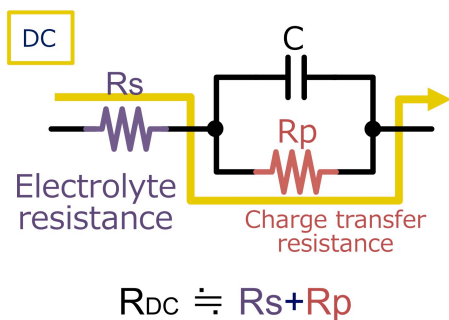
These reactions can be thought of as the equivalent circuit shown on the right of Figure 2. This

understanding of a battery’s internal resistance is helpful in identifying the chemical reactions that occur inside the battery.

**DC-IR AND AC-IR MEASUREMENT METHODS**

In DC-IR measurement, an abrupt current load is placed on the battery while it is in the no-load state, and the resulting voltage drop is measured to calculate the resistance value.

In the equivalent circuit, since the capacitor does not pass the DC current, the current flows through the circuit with the electrolyte resistance and charge transfer resistance, as shown in Figure 3. Consequently, the measured resistance value  $R_{DC}$  combines the electrolyte resistance and the charge transfer resistance. The test is used at production plants as a way to gauge output characteristics.



**Figure 3: Current flow in equivalent circuit**

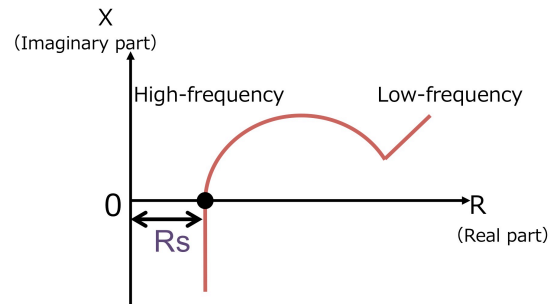
The widely used DC-IR measurement method has a number of issues. First, measurement requires preliminary charging of the battery. Since a large DC current flows during measurement, the battery must be charged prior to testing. This process can take up to one hour. Next, measured values exhibit instability. The timing at which voltage values must be monitored immediately after application of the load is tricky, and measured values resist stabilization. Finally, the DC-IR method requires complex equipment. Testing large batteries used in vehicles may use a current of 100 A or more. Large equipment is required for this task.

In the AC-IR method, an AC signal is applied to a battery and the battery’s internal resistance is then measured. This method is most distinguished by the

fact that it is possible to vary which type of resistance is measured by varying the frequency.

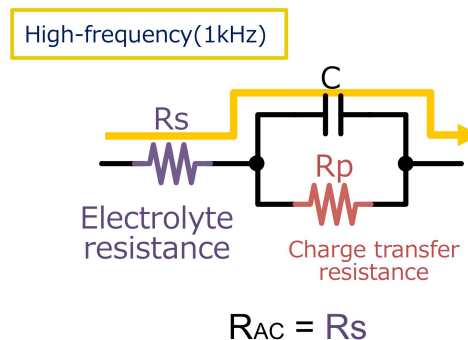
**COLE-COLE PLOT**

In research and development settings, engineers use a graphical method known as the Cole-Cole plot to sweep through a range of frequencies and plot the real and imaginary parts of the impedance. The shape of a Cole-Cole plot can be used to estimate its internal resistance.



**Figure 4: Cole-Cole plot**

For example, if the goal is to obtain the battery’s electrolyte resistance, its impedance is measured at a high frequency. Since capacitors exhibit low resistance to high frequencies, the measurement current takes a path such as that shown in Figure 5. The electrolyte resistance corresponds to the value R at which the Cole-Cole plot’s X value reaches zero.



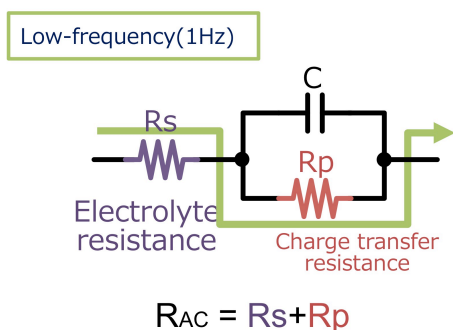
**Figure 5: Current flow in high frequencies**

If the goal is to obtain the charge transfer resistance, the impedance is measured first at a low frequency. Since capacitors exhibit higher resistance to low frequencies, the measurement current takes a path shown on Figure 6. In this way, the measured value is the sum of the electrolyte resistance and the

charge transfer resistance. By subtracting the electrolyte resistance measured previously at a high frequency from this result, it is possible to calculate the charge transfer resistance.

**LOW-FREQUENCY AC-IR TESTING**

Currently, AC-IR measurement in production settings is performed only at the high frequency of 1 kHz but low-frequency measurement is not used. Since the effects of charge transfer resistance can be observed as with DC-IR measurement by performing low-frequency AC-IR measurement, low-frequency AC-IR measurement can be regarded as a viable alternative to DC-IR measurement.



**Figure 6: Current flow in low frequencies**

Using low-frequency AC-IR measurement as an alternative to DC-IR measurement has a number of advantages. First, since no preliminary charging of the battery is necessary, it can dramatically reduce cycle time. Measurement that took several dozens of minutes can be performed in just 10 seconds. In addition, low-frequency AC-IR measurement delivers measured values with increased stability. Finally, since AC-IR measurement can be performed with a minuscule measurement current compared to DC-IR, there is no need for equipment to draw a large current. Measurement that required a 100 A current using the DC-IR method can be performed with a current of just 1.5 A.

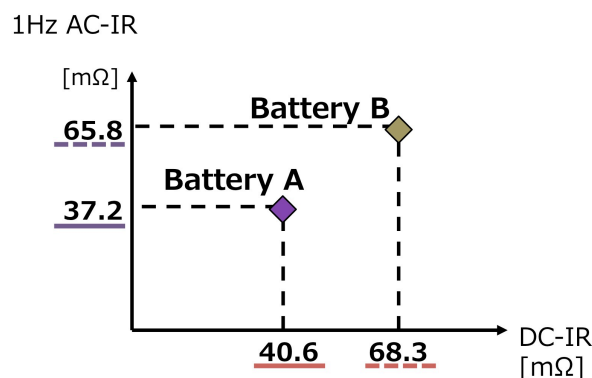
**COMPARISON BETWEEN DC-IR AND LOW-FREQUENCY AC-IR METHODS**

In principle, it is clear that the same battery phenomena are being measured by DC-IR and low-frequency AC-IR measurement. To see if

there is an actual correlation between the measured values yielded by the two methods, the DC-IR measured values and AC-IR measured values of 18650-type cylindrical batteries were compared.

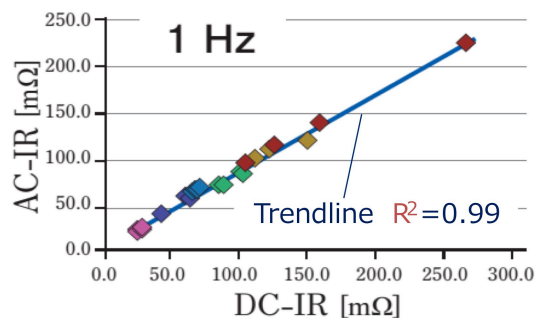
First, a graph is plotted with DC-IR measured values on the horizontal axis and 1 Hz AC-IR measured values on the vertical axis, as shown in Figure 7. Looking at the results for Battery A, the DC-IR measured value of 40.6 mΩ and the 1 Hz AC-IR measured value of 37.2 mΩ can be plotted as a purple point on the graph.

Similarly, the Battery B DC-IR measured value of 68.3 mΩ and 1 Hz AC-IR measured value of 65.8 mΩ can be plotted as the yellow point on the graph.



**Figure 7: Batteries tested with the DC-IR and 1Hz AC-IR methods**

The same tests were conducted on 24 lithium-ion batteries to arrive at the graph shown in Figure 8. Taking the trend line of all 24 points, it is clear that there is a high degree of correlation between the two methods, and that low-frequency AC-IR measurement is valid as an alternative to DC-IR measurement.



**Figure 8: Trend Line of 24 Li-Ion Batteries Tested Using Both Methods**

**DEVELOPMENT OF A LOW FREQUENCY AC-IR MEASURING INSTRUMENT**

This discovery has prompted the development of a low-frequency AC-IR measuring instrument for battery testing.

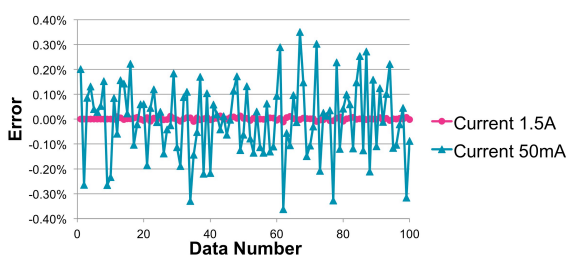
Without the need to charge the battery prior testing, the goal is to develop an instrument that can measure the reliability of a lithium-ion battery in 10 seconds. In addition, a product that has the ability to provide measurement frequencies from 0.1 Hz to 1050 Hz and measure large lithium-ion batteries, which have low impedance values, with a high degree of precision would provide an ideal solution to manufacturers that deliver a wide range of products.

**CHALLENGES TO DELIVERING PRECISE AND STABLE MEASUREMENTS**

The advantages of the AC-IR measurement method are clear, including significantly improved cycle time and a more compact setup. However, the greater challenge is to engineer an instrument that could deliver highly precise, stable measurement. Three issues in particular must be resolved.

**MEASUREMENT CURRENT**

The first is to improve the signal-to-noise ratio in the instrument. To do this, the battery tester is given a maximum measurement current of 1.5 A. Figure 9 illustrates variability in 100 measurements, each consisting of contact and then measurement, of a battery with a resistance value of about 0.65 mΩ.



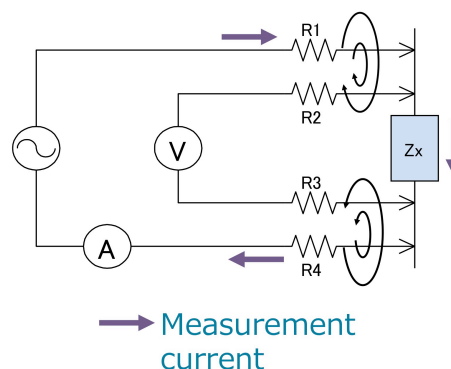
**Figure 9: Repeatability Testing Using 2 Different Measurement Currents**

By using a measurement current of 1.5 A, variability was limited to about ±0.02%, making possible stable measurement of even batteries with

resistance values lower than 1 mΩ.

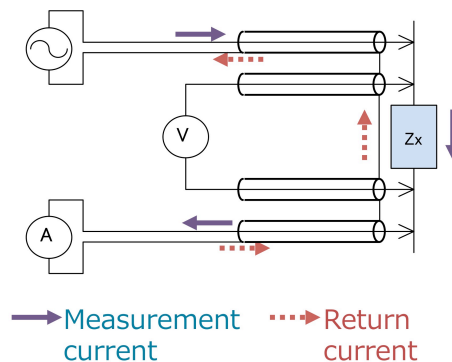
**4-TERMINAL-PAIR METHOD**

The second issue is the measurement method. Generally, an approach known as the 4-terminal method is used when measuring low resistance values. In this method, the measurement current is applied to the current terminals, and the voltage drop across the measurement target is measured at the voltage terminals. This method of measurement is less susceptible to the effects of the probes' contact resistance. However, because it does not safeguard against an inductive field created by the measurement current, that field becomes a measurement error when it enters the voltage terminal loop.

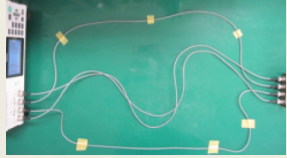
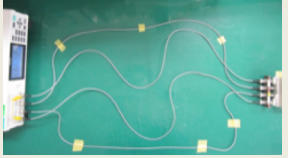
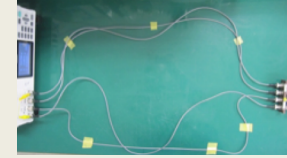


**Figure 10: 4-Terminal Method**

To resolve this issue, a more effective approach known as the 4-terminal-pair method is a more viable solution. In this method, a coaxial cable is used to cancel the inductive field by carrying a current flowing in the opposite direction of the measurement current.



**Figure 11: 4-Terminal Pair Method**

Figure 12: Comparison between the 4-Terminal and 4-Terminal-Pair Methods						
	Route 1 (reference)		Route 2		Route 3	
	R	X	R	X	R	X
4-terminal pair method	0.0000 mΩ	0.0000 mΩ	-0.0002 mΩ	-0.0002 mΩ	-0.0004 mΩ	-0.0011 mΩ
4-terminal method	0.0001 mΩ	0.0001 mΩ	0.2636 mΩ	1.3292 mΩ	0.5806 mΩ	2.9014 mΩ

The 4-terminal-pair method thus enables the measurement of super-low impedance values of less than 10 mΩ with a high degree of precision.

To investigate the actual effects of the 4-terminal-pair method, three cable routes were tested, with Route (1) serving as the reference, or the route with which zero-adjustment was performed. As shown on Figure 12, whereas the measured values vary little when the cable loop is repositioned while using the 4-terminal-pair method, they vary significantly when using the 4-terminal method. The effectiveness of the 4-terminal-pair method in AC measurement of low-resistance devices is clear.

**MEASUREMENT PROBES**

The third challenge to achieving precision and stability is attributed to the measurement probes.

When measuring a low-resistance component, it is necessary to exercise caution with regard to measurement terminal contacts. Since there is a steep potential gradient near the current terminals, measured values are more likely to fluctuate if the distance between the current terminals and the voltage terminals varies.

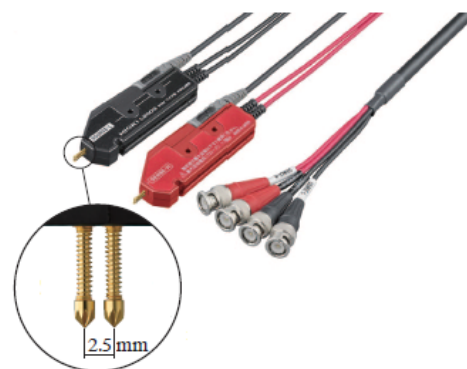
For that reason, it is important to take into account the following three imperatives: Locating voltage terminals and current terminals far apart, keeping the distance between them constant, and using point-based contacts.

Newly developed clip and pin type probes are designed around these three imperatives. Figure 13

shows a clip-type probe for use with laminated batteries, while the Figure 14 shows a pin-type probe designed to make good contact with a variety of batteries.



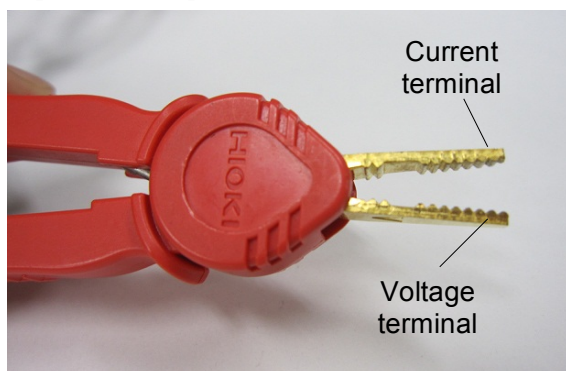
**Figure 13: Newly developed clip type measurement probe with terminals spaced far apart at a constant distance**



**Figure 14: Pin type measurement probe with terminals spaced at a constant distance**

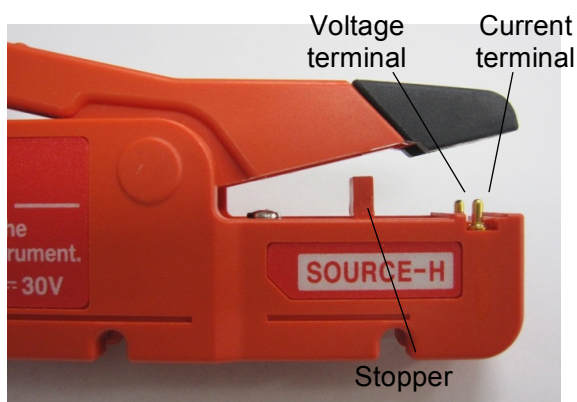
The magnitude of the effect the contact method has on measured values was tested by comparing the reproducibility of measured values between traditional alligator clip probes shown in Figure 15 and the newly developed probe shown on Figure 13. The traditional probe clips serve as the current and voltage terminals, so that the measurement target is

clipped between them. Its clips have a serrated edge to provide multipoint contact.



**Figure 15: Traditional clip measurement probe with voltage and current probes on either side are spaced close together and have multi-point contact**

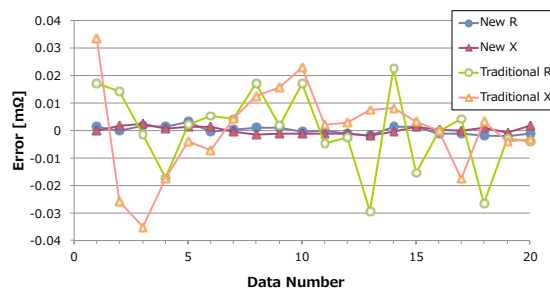
By contrast, as shown on Figure 16, the newly developed clip type probe has one current terminal and one voltage terminal protruding from the bottom of its clip so that contact is made while maintaining a fixed distance between the terminals. The clip also incorporates a stopper to increase reproducibility of the contact position.



**Figure 16: Newly developed probe offers point based contact and a constant distance between voltage and current terminals**

Contact was reestablished for each of the 20 measurements and the reproducibility of the results

was then compared. The measurement target was a laminated lithium-ion battery with a resistance of about 1.4 mΩ.



**Figure 17: Repeatability comparison between traditional clip probes and newly developed clip probes**

Results obtained with the newly developed probes exhibited a deviation of about 2 μΩ from the average value, whereas those obtained with the traditional clip probes exhibited a divergence of about 40 μΩ. It is clear that measurement reproducibility can be improved by observing certain precautions when establishing contact. In fact, those precautions are essential in order to measure low impedance batteries with a high degree of precision.

Low-frequency AC-IR measurement is effective as an alternative to the DC-IR approach to output characteristics testing in battery testing processes. It can be expected to enable operators to shorten cycle time in production settings, improve measurement precision, and shrink the size of required equipment.

Copyright © Akihiro Narusawa  
 HIOKI E.E. CORPORATION  
 All rights reserved.  
 May 30, 2015